

M3 TRENCH KNIFE

THE M3 KNIFE WAS DEVELOPED IN 1943 FOR OUR FIGHTING MEN, AND WAS MANUFACTURED BY AT LEAST NINE DIFFERENT KNIFE COMPANIES. PROGREMENT RECORDS AT THE ROCK ISLAND ARSENAL INDICATE THAT THE GOVERNMENT PURCHASED 2,590,240 OF THESE KNIVES DURING THE YEARS 1943 AND 1944.

TODAY THE M3 IS A MUCH SOUGHT AFTER KNIFE BY COLLECTORS, AND EVEN WITH THE HIGH PRODUCTION FIGURE IT IS A SCARCE AND HARD TO FIND ITEM.



THE H. BOKER & CO. NEW YORK PRODUCED THE LOWEST NUMBER OF THESE KNIVES. 31,300, WHILE THE IMPERIAL KNIFE CO. MADE THE LARGEST NUMBER 854,015.

AT FIRST THESE KNIVES WERE STAMPED ON THE BLADE MAKERS THE DATE WERE MADE. WERE GUARD TO PREVENT WEAKENING OF THE BLADE FROM THIS STAMPING.

U.S.M3 CASE 1943

"U.S. M3" WITH THE NAME AND SOMETIME 1943, THE YEAR THEY THE LATER KNIVES STAMPED ON THE

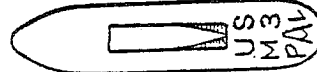

THE ORDNANCE DEPT. SPECIFICATIONS FOR THE M3 TRENCH KNIFE DATED DEC 30, 1942 CALL FOR A GRIP OF LEATHER WASHERS CUT WITH SIX GROOVES FOR BETTER GRIPPING, BUT ALONG WITH THE SIX GROOVED SPECIMENS WE FIND OTHERS WITH SEVEN GROOVES, AND MOST OF THEM HAVE AN EIGHT GROOVE HANDLE. ALONG WITH THE GROOVED VARIETY WE FIND SOME WITH PERFECTLY SMOOTH HANDLES. THE "CASE CO." MADE ONE MODEL WITH EIGHTEEN OVAL RIDGES CUT IN THE HANDLE WHICH GIVES A VERY GOOD FEEL.

THE "CASE CO." MADE MORE VARIATIONS OF THIS MODEL KNIFE THAN ANY OTHER MANUFACTURER. THESE VARIATIONS INCLUDED TWO DIFFERENT BLADE MARKINGS, AND TWO GUARD MARKINGS. SOME HAD A BENT GUARD, AND OTHERS WERE STRAIGHT. THE HANDLE VARIATIONS, WERE SMOOTH, RIDGED, AND GROOVED TYPES, IN GENERAL THE BLADES AND BUTTS USUALLY CONFORMED WITH THE SPECIFICATIONS ON THIS KNIFE.

COLLECTION OF M.H. COLE

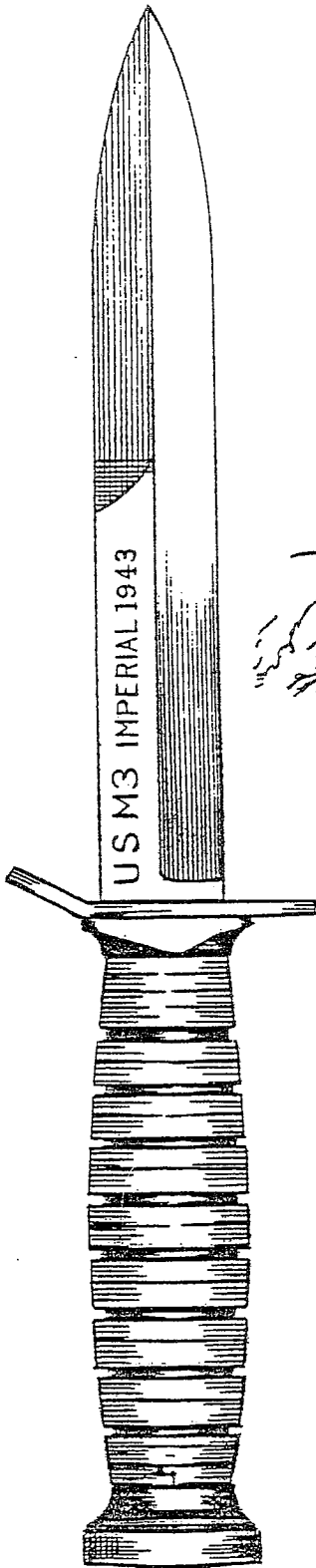

M. H. COLE

71

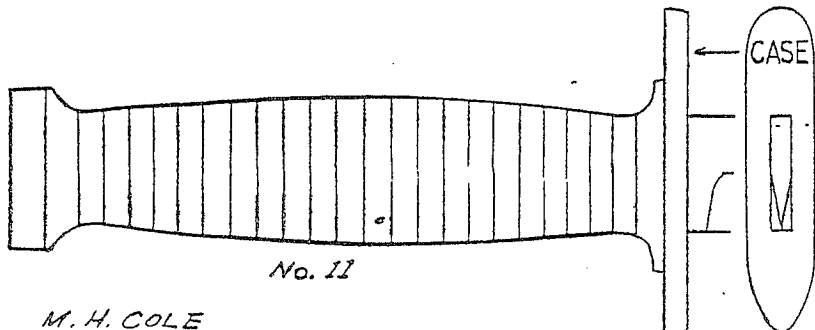
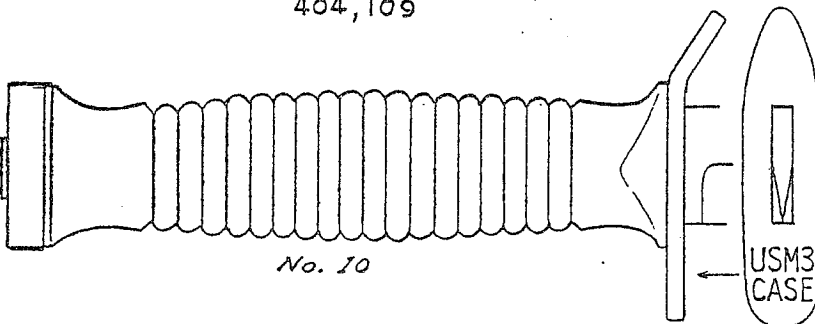
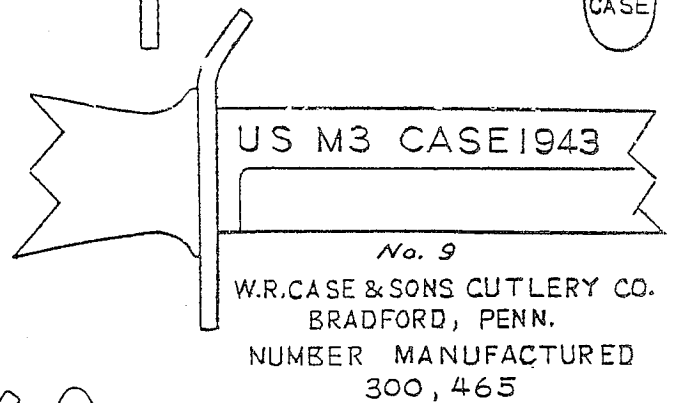
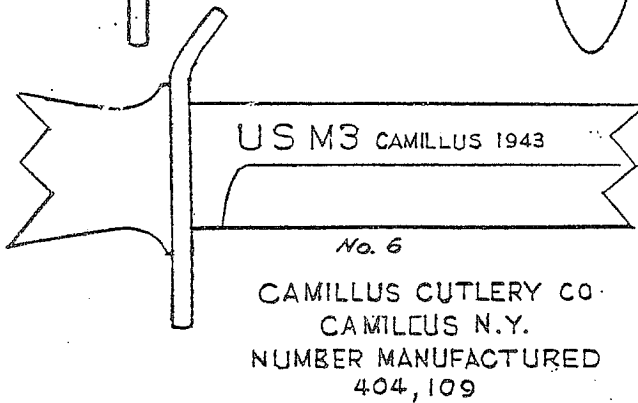
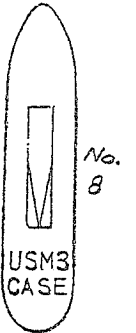
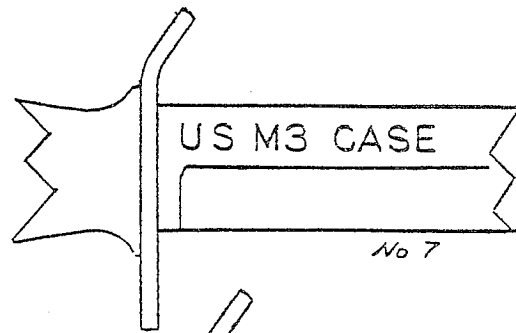
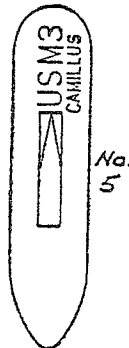
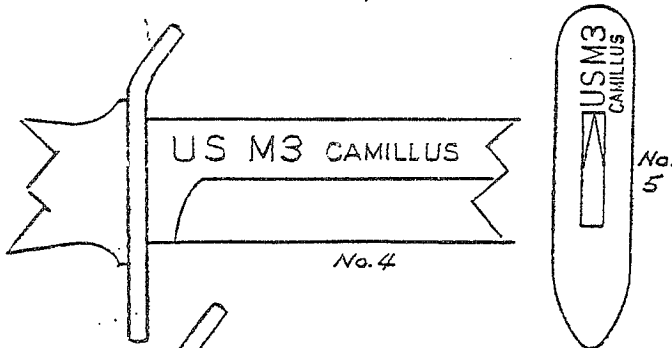
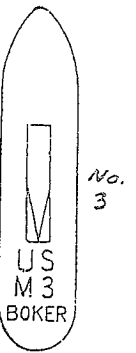
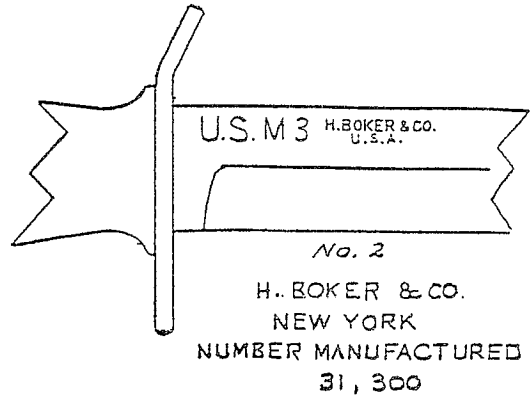
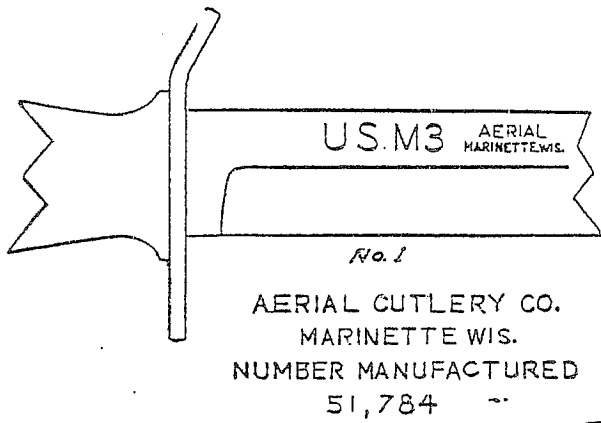

M3 TRENCH KNIFE

THE PRODUCTION FIGURES ON THIS KNIFE WERE OBTAINED FROM THE PROCUREMENT RECORDS OF ROCK ISLAND ARSENAL, R. I. ILL. UNFORTUNATELY THESE RECORDS DO NOT SHOW THE NUMBER THE GOVERNMENT GOT FROM THE UTICA CUTLERY CO., BUT ADDING UP THE TOTAL FROM THE OTHER COMPANIES AND SUBTRACTING IT FROM A TOTAL OF 2,590,240 WE HAVE LEFT A FIGURE OF 655,230 WHICH IS ABOUT RIGHT FOR THE NUMBER PRODUCED BY "UTICA". IN A LETTER FROM THE "UTICA CO. DATED OCT. 7, 1970 THEY STATE THAT THEY MANUFACTURED OVER ONE HALF MILLION M3'S

M. H. COLE
71

COLLECTION OF ADRIAN VAN DYK

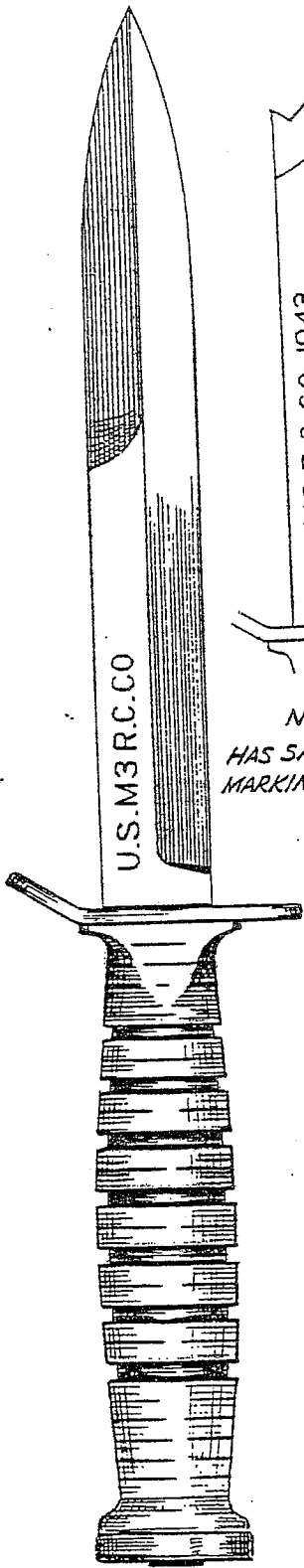

U.S.M3 R.C.CO

No. 26
HAS SAME GUARD
MARKING AS No.21

M.H. COLE
71

No. 21

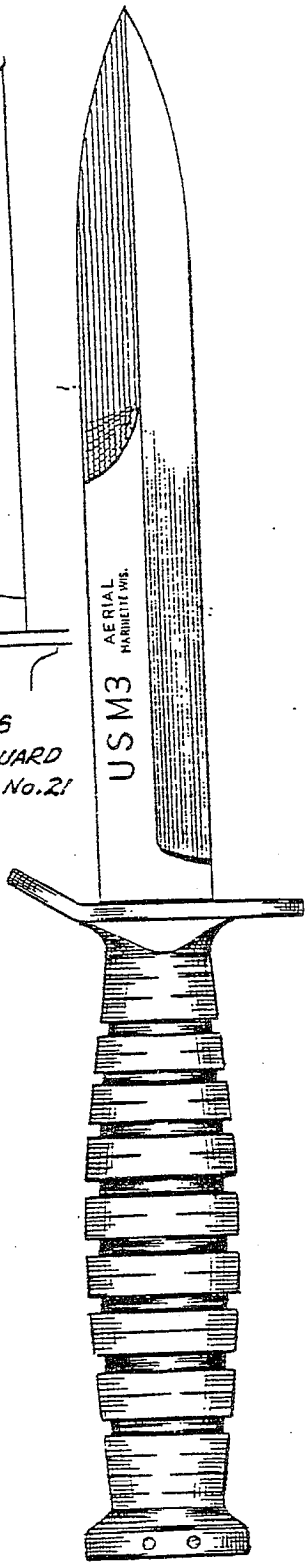
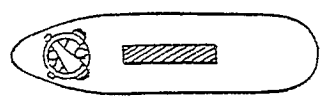

USM3
AERIAL
PARLIETTE WKS.

No. 1

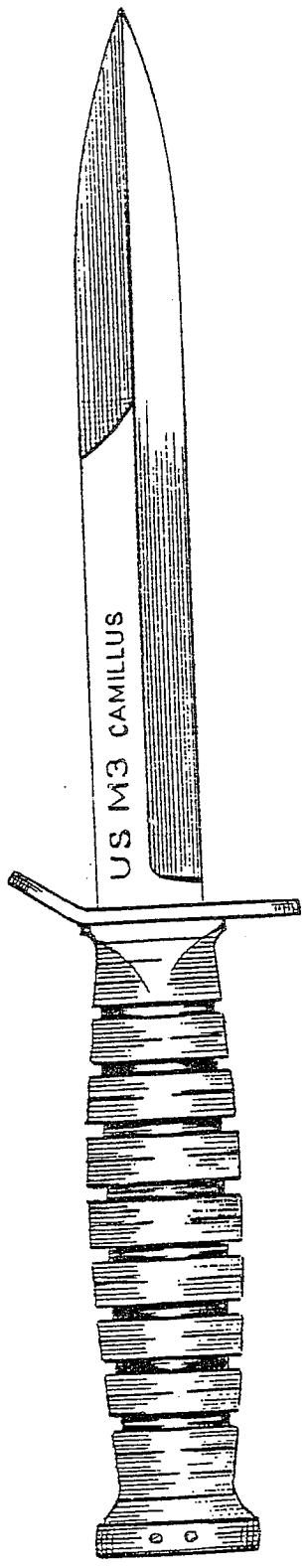
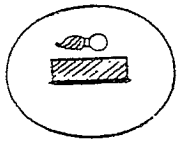

US M3 CAMILLUS

No. 4

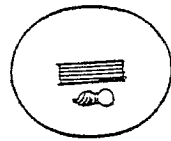

COLLECTION OF ADRIAN VAN DYK

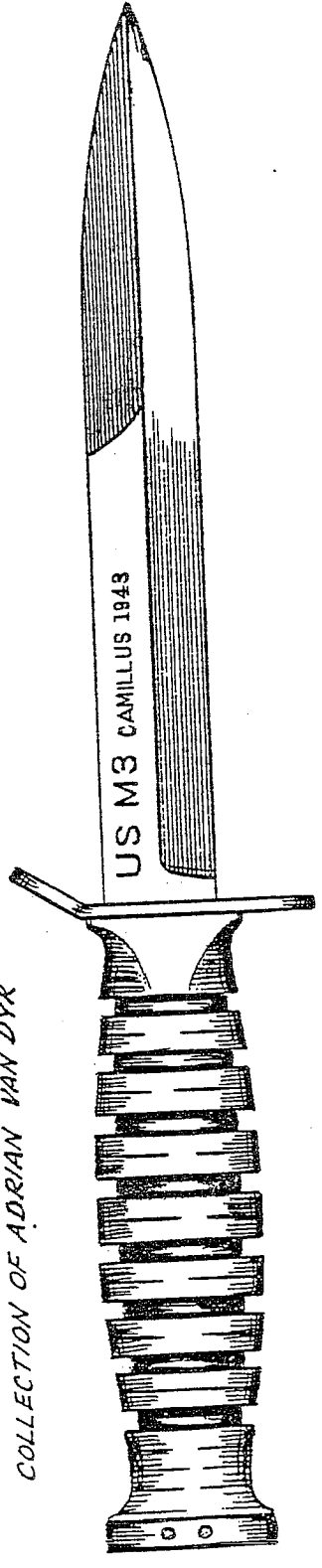

US M3 CAMILLUS 1943

No. 6

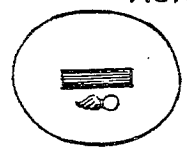

— SCABBARD, TRENCH KNIFE M6 —

DEVELOPED IN 1943 FOR THE M3 TRENCH KNIFE WHICH IS SHOWN IN THE ORDANANCE DEPT. DRAWING DATED JAN. 2 1943. THE SPECIFICATIONS CALLED FOR A LEATHER BODY 15 7/8" IN LENGTH, AND THROAT TO HAVE 8 METAL BELT LACES FOR REINFORCEMENT. THE LOWER PART OF THE SCABBARD WAS TO HAVE A STEEL PLATE RIVETED TO THE FRONT AND BACK OF LEATHER TO PROTECT THE WEARER FROM THE BLADE TIP. THE M6 SCABBARD PROVED TO BE UNSATISFACTORY AND A NEW SCABBARD WAS DEVELOPED THE M8 MADE OF PLASTIC.

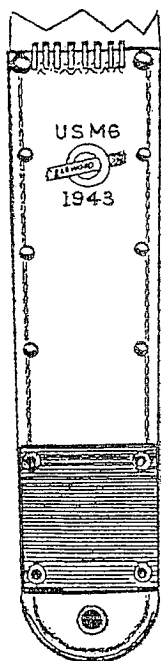

No. 1

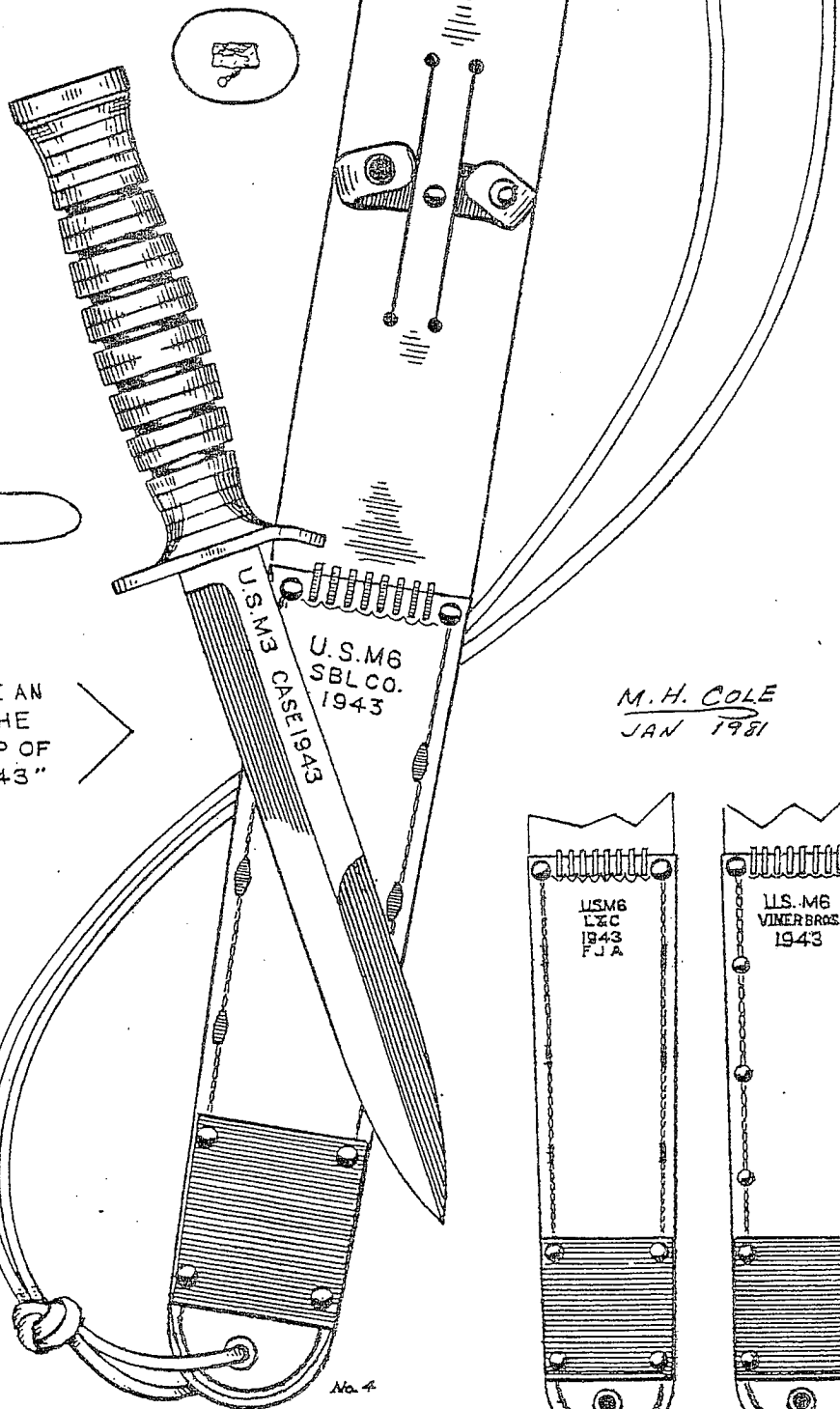

No. 4

A KNIFE COLLECTORS DREAM. KNIFE AN SCABBARD ARE STAMPED WITH THE MODEL DESIGNATION & "U.S.". ON TOP OF ALL THIS, BOTH ARE DATED "1943"

M. H. COLE
JAN 1981

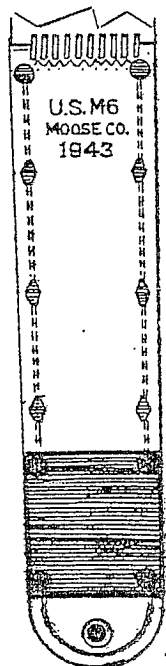

No. 2

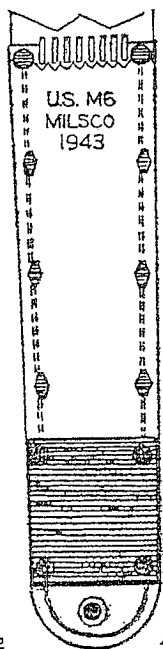

No. 3

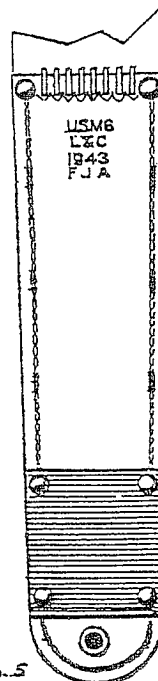

No. 5

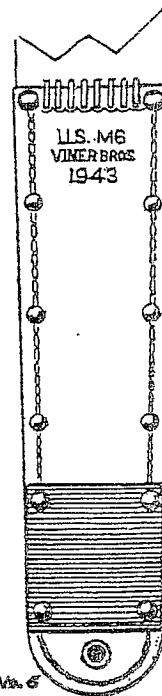

No. 6

12/30/43

U.S. ARMY
ROCHESTER ORDNANCE DISTRICT

Govt No. M3
Our No. 5682 L 75

With scabbards furnished by
the Government. M6
* (Changed to M8 plastic)

DESCRIPTION - 6-3/4", Parkerized, double edge blade, steel guard,
steel butt, leather handle

SPECIFICATIONS - Drawing # 20-2B-52 dated 12/30/42

CHANGES - revised drawing with minor radius changes 11/13/43

OTHER MANUFACTURERS: Imperial, Utica, W.R. Case, Kinsfolk, Pal,
Aerial Cutlery, Robeson

USES - Utility knife used by certain ground forces of the AAF,
Tank Units and specialized Commando units.

CONTRACTS - Camillus: 35,900; 113,000; 117,000;
137,009; *Total 402,909*

Others: Received approximately 1,500,000

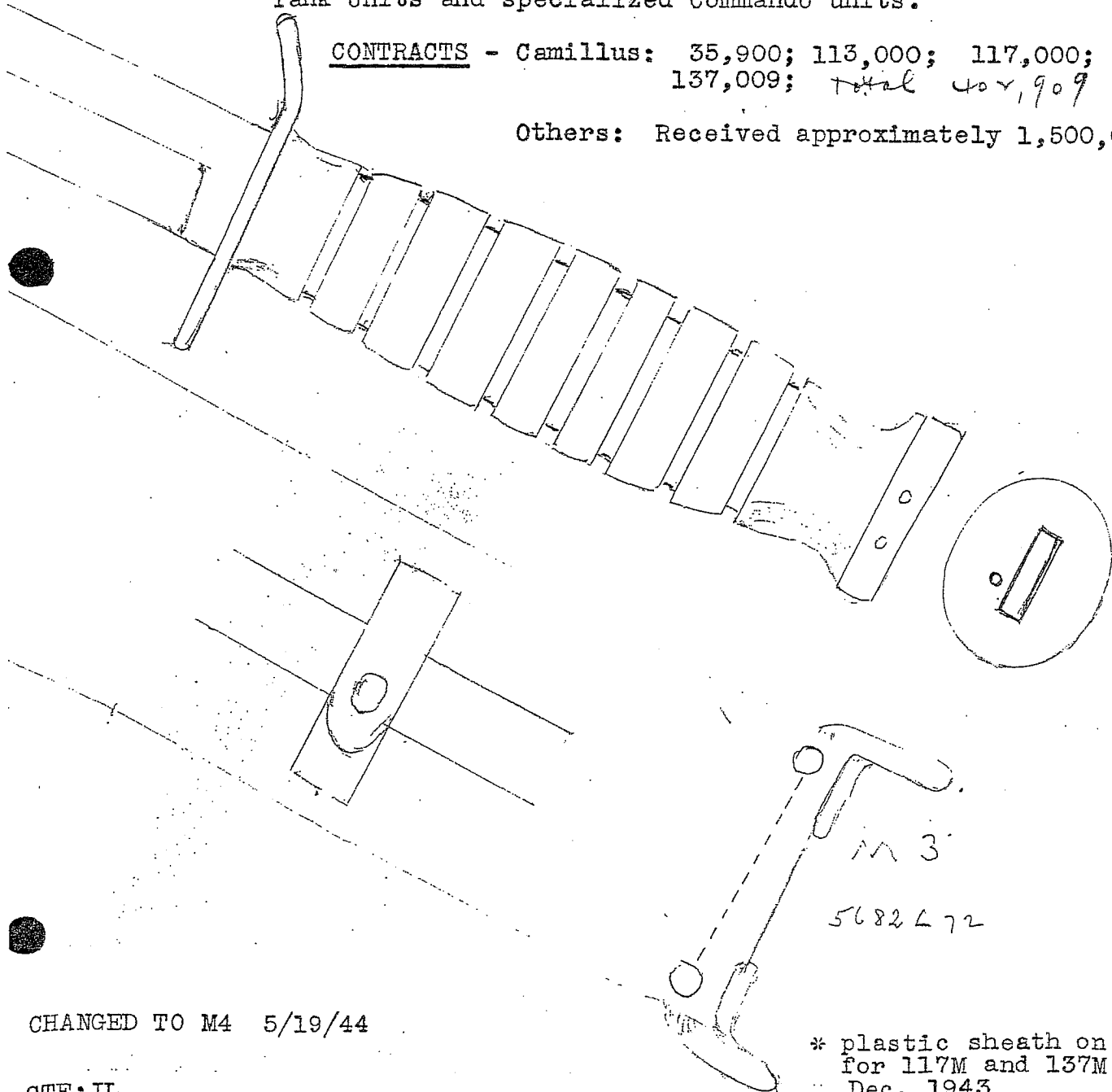

CHANGED TO M4 5/19/44

CTF:JL

* plastic sheath on contracts
for 117M and 137M
Dec. 1943

M3

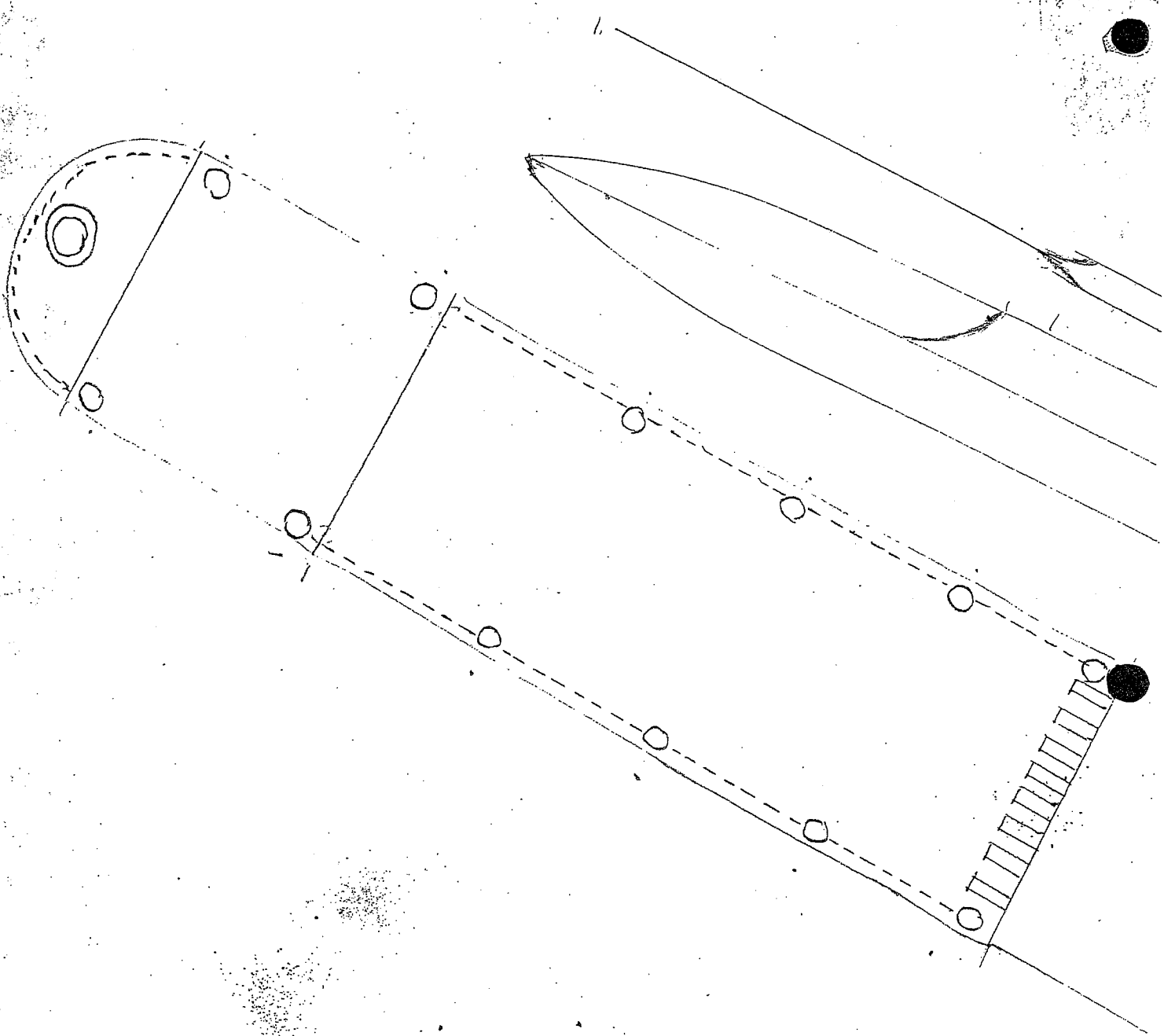

5682 L 72

Trench Knife

Blades				Stamp	Handle	Shield
No.	Pocket	Pen		MS Shield No.	M/S	
5682				PS Shield No.	P/S	
Point				Cutler Quality	Blade Fin.	
Nail Mark		3/16"		Harting		
Gauge		3/16" Steel		Covering	LEATHER Washers - 2 Sizes #2 & #3	
Swage M/S	Com	See		/1000	from Simplex Mfg. Co. Aut.	
Swage P/S	Com	Reverse		/1000	9/10 43 9/16 #8 27 lbs #3	
Blade Die	5682			Remarks	Butt Purchased from Square Stamping Co. - 1/4" Hot Rolled Steel SAE 10-10	
Tang Die						
Tang Finish						
Blade Finish	GLA & PARKERIZED					
Handle						

Handle in Butt & Tang
 #38 drill - 13 ga pins

BOLSTER SCALES	SPRINGS	POCKET	PEN	ETCHED
No. Guard 1/8" C/R Steel	Die No.			BL. STAMPED U.S.M3 CAMILLUS 1943
Lining Die Guard Bent	Gauge			Clevice
Lining Material	Paint or Color			Center Scale
Bolster Material	Reg. or F. B.			No.
Tip Material	Handle			Material
Bolster Tip/1000				Gauge

Sample Date: Order # Y2508
 Account of: Spec. # AXS-865 Ord. Dept. Blue Print #20-2B-52
 Form F3 2M 1-42

5682 L 72

Trench Knife

Blades				Stamp	Handle	Shield
No.	Pocket	Pen		MS Shield No.	M/S	
5682				PS Shield No.	P/S	
Point				Cutler Quality	Blade Fin.	
Nail Mark				Harting		
Gauge		3/16" steel		Covering	Leather Washers - 2 sizes over	
Swage M/S	Com	See		/1000	from Simplex Mfg. Co. Aut.	
Swage P/S	Com	Reverse		/1000		
Blade Die	5682			Remarks	Butt purchased from Square Stamping Co. 1/4" Hot Rolled Steel	
Tang Die						
Tang Finish						
Blade Finish	Blat parkerized					
Handle					Blade stamped U.S.M3 Camillus 1943	

Handle in butt & tang
 #38 drill - 13 ga pins

BOLSTER SCALES	SPRINGS	POCKET	PEN	ETCHED
No. Guard	Die No.			
Lining Die 2 1/2 x 1/8" C/R Steel	Gauge			Clevice
Lining Material Guard bent	Paint or Color			Center Scale
Bolster Material	Reg. or F. B.			No.
Tip Material	Handle			Material
Bolster Tip/1000				Gauge

Sample Date: Order # Y2508
 Account of: Spec. # AXS-865 Ord. Dept. Blue Print #20-2B-52
 Form F3 2M 4-39

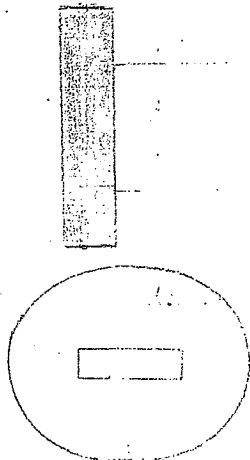
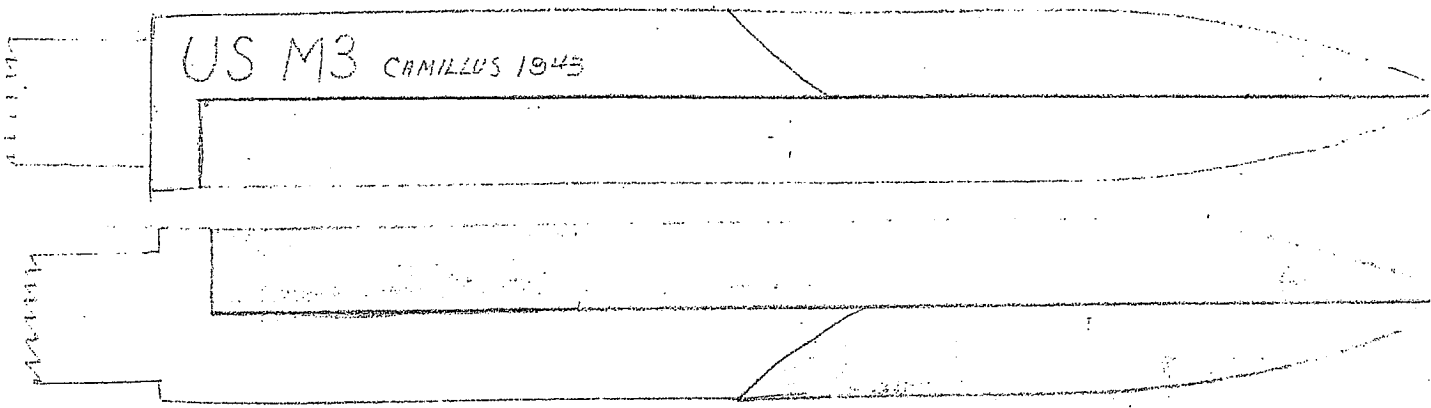

#2 Small = small leather washer (2 ³/₄ lbs. per gr. knives)
 #3 large - large " " (17 ³/₄ " " " ")

#2 Small discontinued 8/10/43

#3 large 27 lbs = 1 gross of knives 8/28

#8 (to knife) 9 ¹/₂ bags = 1 gross 9/10/43

5682L72 A. = Stamped guard, US M-3
 Camillus
 No stamping on blade.

Stamped *Side of Blade* Handle Shield

M3 TRENCH KNIFE

Blades	Pocket	Pen	MS Shield No.	M/S	11/27/42				
No. 5682			PS Shield No.	P/S	U.S. M3 CAMILLUS 706				
Point			Cutler Quality	Blade Fin.					
Nail Mark			Hafting	Handle	Turned dimensions - see blue part.				
Gauge	7/8" x 3/16" x 14"	Long. Multiples 12"	Covering	32-33-#3	37" Grs	7 Simplex, Auburn			
Swage M/S	Com (Blue Pat.)	.86 lb./grs.	1/1000	1-#8	9 1/2 oz. Grs				
Swage P/S	Com	.95-1.05 carbon	1/1000			1/2" x 7/8"			
Blade Die			Remarks	Butt purchased from Square Stamping Co. res.					
Tang Die	2 holes in end of blade #38 drill			Steel purchased from Edgcomb Steel Co. - 35# U.S.					
Tang Finish	hole in tang #155	2" from end of tang		1 3/4" x .250 x 96" long. Hot rolled, pickled & oiled					
Blade Finish	Shield D.H. mach buffed - parkerized			See 1010 - soft - Shearid. Edge. 2 holes #38 drill					
Handle	Leather	Rockwell 52.56		Butt Stamped "Flaming Bomb" Parkerized					

BOLSTER SCALES	Guard	SPRINGS	POCKET	PEN	ETCHED				
No.	#5682	Die No.	2 pins =	1 3/8" x .095					
Lining Die	Brace Muller Rome Strip Steel	Gauge	Wickwire =	5.02 Grs. Single	Clevice				
Lining Material	2 1/2 x .125 Cr	Paint or Color			Center Scale				
Bolster Material	S.A.E. 1010 1/4 hard	Reg. or F. B.			No.				
Tip Material	10' long	Handle			Material				
Bolster Tip/1000	Bent - Parkerized				Gauge				
Sample Date	8 1/2 lbs/grs.	Account of	Spec. # AXS-865 ord. dept.	Blue Pat. # 20-2B-52	Form F3 2M 1-42	SAMPLE	C. C. C.	N. Y.	Customer

5682-L72

Trench Knife

Blades	Pocket	Pen	MS Shield No.	M/S	Stamped	Handle	Shield
No. 5682			PS Shield No.	P/S			
Point			Cutler Quality	Blade Fin.			
Nail Mark			Hafting				
Gauge		3/16" Steel	Covering	LEATHER Washers - 2 sizes #2 & #3			
Swage M/S	Com	See	1/1000	from Simplex Mfg. Co. - Auburn			
Swage P/S	Com	Reverse	1/1000	9/10/43 9 1/2 oz. #8 27 lbs. #3			
Blade Die	5682		Remarks	Butt Purchased from Square Stamping Co. - 1/4" Hot Rolled Steel S.A.E. 10-10			
Tang Die							
Tang Finish							
Blade Finish	GLA & PARKERIZED						
Handle							

BOLSTER SCALES	Guard 1/8" Cr Steel	SPRINGS	POCKET	PEN	ETCHED	Bl. STAMPEO U.S. M3 CAMILLUS 943			
No.		Die No.							
Lining Die	GUARD Bent	Gauge			Clevice				
Lining Material		Paint or Color			Center Scale				
Bolster Material		Reg. or F. B.			No.				
Tip Material		Handle			Material				
Bolster Tip/1000					Gauge				
Sample Date	Order #	Account of	Spec. # AXS-865 Ord. Dept.	Blue Paint # 20-2B-52	Form F3 2M 1-42	SAMPLE	C. C. C.	N. Y.	Customer

Guard stamped US M3 1/27/43 SSS

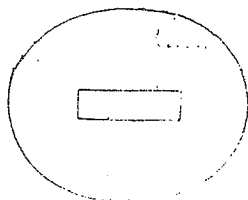
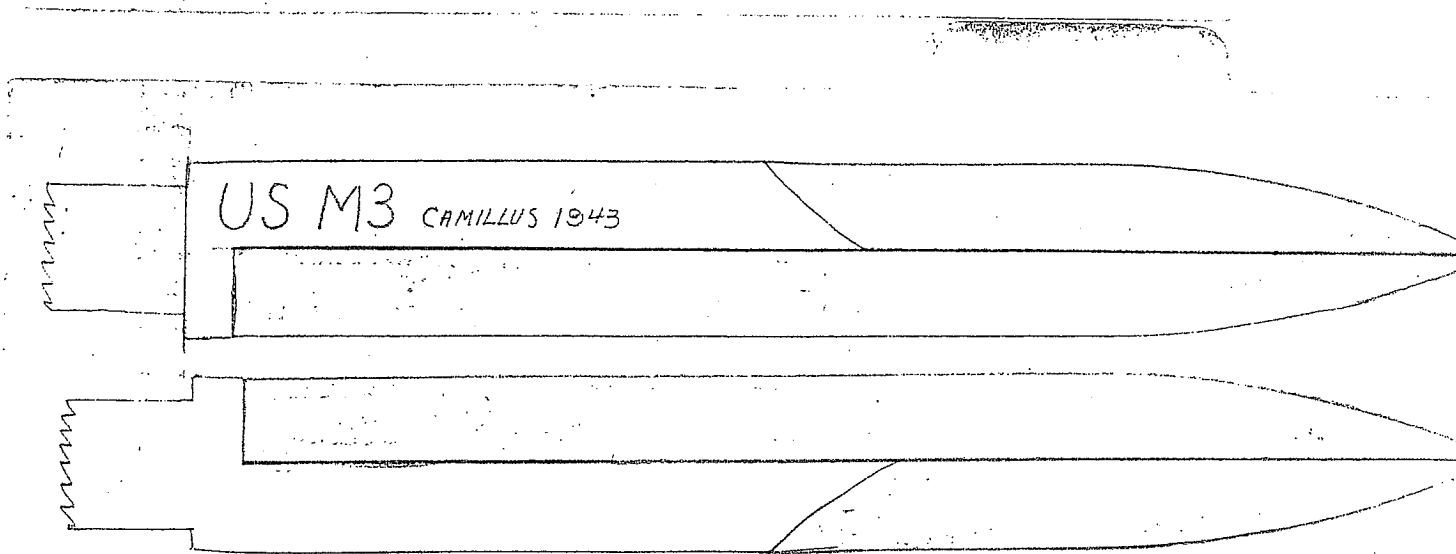

Trench Knife

BLADES	POCKET	PEN	MS SHIELD NO.	M/S
NO. 5682			PS SHIELD NO.	P/S
POINT			CUTLER QUALITY	BLADE FIN.
NAIL MARK			HAFTING	
GAUGE 7 $\frac{3}{16}$ " steel			COVERING	Leather Washers - 2 sizes over from Simplex Mfg. Co. Ont.
SWAGE M/S com			71000	
SWAGE P/S com			11000	
BLADE DIE 5682			REMARKS	Butt purchased from Square Stamping Co. 14 Hot Rolled steel
TANG DIE				
TANG FINISH				
BLADE FINISH Glazed parkerized				
HANDLE				Blade stamped U.S.M3 Camillus 19

Valves in handle of tang #38 drill - 13 ga frame

BOLSTER	SCALES	SPRINGS	POCKET	PEN	ETCHED
NO. Guard		DIE NO.			
LINING DIE $2\frac{1}{2} \times \frac{1}{8}$ C/R Steel		GAUGE			CLEVICE
LINING MATERIAL Guard bent		PAINT OR COLOR			CENTER SCALE
BOLSTER MATERIAL		REG. OR F. B.			NO.
TIP MATERIAL		HANDLE			MATERIAL
BOLSTER TIP/1000					GAUGE

Order # Y2508 Spec. AXS-865 Ord. Dept. ACCOUNT OF Blue Print #20-2B-52

FORM F3 2M 4-39

5682 272

TRENCH KNIFE

Blades	Pocket	Pen	Stamped	Side of BLADE.	Handle	Shield
No. 5682			MS Shield No.	M/S	US M3 CAMILLUS	
Point			PS Shield No.	P/S		
Nail Mark			Cutler Quality	Blade Fin.		
Gauge $7/8" + 3/16"$ $\times 14'$ LONG. MULTIPLES 12"			Hafting	HANDLE TURNED DIMENSIONAL - SEE BLUE PRT.		
Swage M/S COM (BLU. PRT) .86 lbs/grs.			Covering	32-33 - #3, 27* GRS. } Simplex, HO BURN		
Swage P/S COM " " .95 - 105 CARBON			11000	1 - #8 9/202. GRS.		
Blade Die			11000			
Tang Die 2 HOLES IN END OF BLADE - #38 DRILL			REMARKS	BUTT PURCHASED FROM SQUARE STAMPING CO. STEEL PURCHASED FROM EDG COMB STEEL CO. - 25* GRS.		
Tang Finish HOLE IN TANG. 1/8" 2" FROM END OF TANG				1 3/4" \times .250 \times 96" LONG. HOT ROLLED, PICKLED + OILED		
Blade Finish GLAZED - D.H. MACH. BUFFED - PARKERIZED.				SAE 1010 - SOFT - SHEARED EDGE. 2 HOLES #38 DRILL		
Handle LEATHER				BUTT STAMPED "FLAMING BOMB" - PARKERIZED		

BOLSTER	SCALES	SPRINGS	POCKET	PEN	ETCHED
NO. *5682		DIE NO.	2 PINS = $1\frac{3}{8}$ " \times .095		
Lining Die BRUCE MUELLER ROME STRIP STEEL.		GAUGE	Wickwire = 5.02 GRS. SINGLE		CLEVICE
Lining Material $2\frac{1}{2} \times .125$ C/R		PAINT OR COLOR			CENTER SCALE
Bolster Material S.A.E 1010 1/4 HARD		REG. OR F. B.			NO.
Tip Material 10' LONG.		HANDLE			MATERIAL
Bolster Tip/1000 BENT - PARKERIZED					GAUGE

8 1/2 LBS/GRS. SPEC. *AXS-865 ORD. DEPT ACCOUNT OF BLU PRT. #20-2B-52

FORM F3 2M 1-42

Small = small leather washer (2³/₄ lbs. per gr. knives)
large - large " " " " (17³/₄ " " " ")

#2 Small discontinued 8/10/43

#3 large 37 lbs = 1 gross of knives 8/28

#8 (to knife) 9¹/₂ lbs = 1 gross 9/10/43

5682 L72 A = Stamped guard, USM-3
Camillus
No stamping on blade.

5682 L72 A - NO STAMPING ON BLADE

14/4/43
(I.S.M.T.H.)

USM 3 - STAMPED ON GUARD